

On-Site Applications of Advanced Diagnosis Methods for Quality Assessment of Insulation of Power Transformers

M. Hässig¹, R. Bräunlich¹, R. Gysi², J.-J. Alff³, V. Der Houhanessian³, W. S. Zaengl³

¹FKH Fachkommission für Hochspannungsfragen, CH-8044 Zurich, Switzerland

²NOK Nordostschweizerische Kraftwerke, CH-5401 Baden, Switzerland

³ALFF ENGINEERING, CH-8915 Hausen am Albis, Switzerland

Abstract: On-site diagnosis methods for quality assessment of large power transformers rise in importance, as deregulation of the energy market demands an improved life time management for expensive equipment. Here, the three complementing methods in use in Switzerland are discussed: Off-line partial discharge diagnosis (PD), frequency response analysis (FRA) and polarisation / depolarisation current measurements (PDC). For PD and for FRA noteworthy experience exists already. However, the PDC method became only recently available as an user-friendly method; its aptitude is described in detail and it is shown how to obtain information on the integral condition of the oil-cellulose insulation system from PDC measurements.

Introduction

The operational availability of large power transformers is of strategic importance for power generation and transmission companies. Serious failures in power transformers owing to insulation breakdown cause considerable financial losses due to power outage and costs for replacement or repair. Therefore, most power utilities have developed individual inspection methods and schemes for the transformer condition assessment and they traditionally collect duty time percentage data and information on failure causes. An international survey of CIGRE [1, 2], shows typical failure rates for large power transformers for operating voltages up to 300 kV in the range of 1% to 2% p.a.

Although power transformers show a satisfactory reliability, there exists an interest for further reduction of the failure rate. Likewise an improvement of transformer condition assessment renders benefit by giving a decision basis for the logistic management. Thus current efforts concentrate to:

1. A better understanding of the ageing behaviour of the oil-cellulose insulation system.
2. Refining the diagnostic techniques to improve the reliability of the prognosis and to progress the development of clear rules for the interpretation of diagnostic results.

3. Collecting and filing of statistical data of diagnostic results, service data and failures.
4. Promotion of a consequent acquisition of initial commissioning data of all relevant diagnosis parameters for later comparison.

An important motivation for the efforts to develop and apply better diagnostic methods and tools for assessing the condition of large power transformers is the increasing age of the transformer population. The majority of large power transformers in Switzerland and most other countries in central Europe were installed in the 60's and 70's.

Diagnosis techniques for transformer insulation may be divided in electrical and non-electrical methods or in on- and off-line methods (monitoring and diagnosis). They also may be divided in methods characterising the integral (overall) state and those characterising weakest points (local defects) of the insulation system. In [3] a discussion of the most common methods was published. Whereas oil analysis and dielectric relaxation measurements render information on the average insulation condition, only the partial discharge tests (PD-measurements) and the frequency response analysis (FRA-method) are sensitive to local defects.

The different insulation diagnosis methods are also complementary, as potential measuring errors or uncertainties have different origins and can thus be detected and corrected [4].

While traditional and standardised diagnosis methods, in particular the oil examinations [5, 6, 7], are still an important basis for the observation of insulation ageing, the authors are practising the following three innovative and meaningful methods, that are the main issue of this contribution:

- **Measurement of relaxation currents, i.e. polarisation and depolarisation currents (PDC)** (ageing under thermal stress, humidity in cellulose);
- **Measurement of partial discharges (PD)** (electrical stress, local defects in HV insulation);
- **Measurement of transfer function (FRA)** (effects of mechanical stress, deformation of windings).

The following description demonstrates the experience and implications made from the

mentioned methods mainly in Switzerland and adjacent countries.

PDC Measurements

The measurement of polarisation and depolarisation currents (PDC) is a new, simple and direct method for the quality assessment of power transformer insulation systems. With this method, the "dielectric response function" of the composite oil-cellulose insulation system is quantified within the most essential part of the time domain and all significant parameters of the different parts of the insulation can be evaluated by adequate post processing.

The measurement experience as gathered by FKH and during earlier investigations [8] have shown that the PDC method can well be applied under on-site conditions with an adequate instrumentation which now is commercially available.

In this section, the capability of the PDC method is demonstrated by means of measurements performed on two powerful generator step up transformers designed for the installation at Beznau nuclear power station which is operated by NOK. The two transformers can be characterised by the following data:

- "Used" unit: 3-phase 251/15.5 kV 220 MVA, manufactured in 1967 and since its installation most of the time fully loaded with scheduled stop every summer.
- "New" unit: 3-phase 245/16 kV 230 MVA, manufactured in 2000 and which replaced the former unit.

The measurement of relaxation currents was carried out with a "PDC-analyser-1MOD" manufactured by ALFF ENGINEERING [9]. According to the "two active electrodes" measuring technique as used in this analyser [10], for each transformer, the excitation voltage was applied on the outer high voltage windings and the currents were sensed from the inner low voltage windings. This kind of connection, which is indicated in Figure 1, permits a selective measurement of the main insulation between the low and high voltage windings.

The main insulation of the investigated transformers consists, as usual, of a series of pressboard barriers with oil ducts and axial pressboard spacers in between, the latter separate the barriers mechanically [11]. It is evident that the shape of measured relaxation currents must then be dependent on the different dielectric properties of oil and pressboard material and on their geometrical layout.

The results of these measurements are presented in Figure 2. For both transformers a charging voltage of 1 kV was chosen. The polarisation duration for the new

unit was 10'000 s and for the used one, due to time restrictions, was 6'000 s. The same time periods have been applied for the measurements of the depolarisation currents. The oil temperatures during the measurement are indicated in Figure 2. The characteristic, initially predominant exponential shape of the measured currents is due to the exponential time dependence of the interfacial polarisation and depolarisation currents as caused by the series arrangement of the oil ducts and pressboard barriers. For long times of voltage application, the dielectric response of pressboard barriers becomes more apparent due to the completion of this interfacial polarisation. Also the small contribution of the currents generated by the spacers influences mainly the shape of the resulting currents at long times [8].

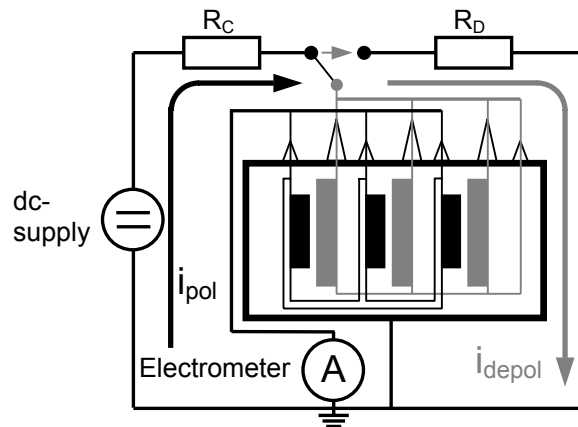

Figure 1: Measurement of the polarisation and depolarisation currents on a power transformer with the "two active electrodes" technique [10].

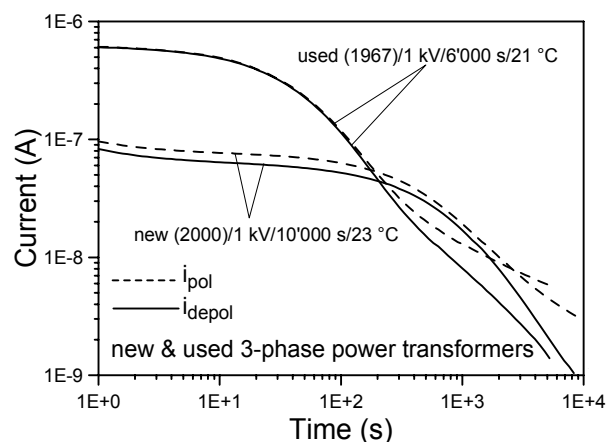

Figure 2: Measured polarisation and depolarisation currents on a new 3-phase 245/16 kV 230 MVA power transformer manufactured in 2000 and a used 3-phase 251/15.5 kV 220 MVA unit manufactured in 1967.

Based on extended linear models which take the geometrical design of the main insulation into account [8, 11], it is possible to distinguish between the dielectric properties of oil and pressboard and consequently to simulate the polarisation and depolarisation currents for different dielectric properties of oil and pressboard.

The results of evaluations presented in the Figures 3 to 6 have been determined with the evaluation software delivered with the PDC-analyser called "PDC-Evaluation Program".

Figure 3 presents the results of the simulation based on an extended model. Here, the measured polarisation and depolarisation currents of the *new* transformer already presented in Figure 2 are matched to a set of simulated currents at 23 °C in function of different moisture content in the pressboard barriers and spacers. For these simulations the required dielectric quantities of oil (i.e. conductivity and power frequency permittivity) are set constant and those of pressboard, i.e. dc conductivity, power frequency permittivity and dielectric response function, are changed according to the moisture content [8, 11, 12]. These latter quantities are taken from well controlled laboratory measurements performed on the corresponding pressboard material.

From the time dependence of the simulated currents it can be seen that the moisture content of pressboard influences mainly the shape of the polarisation and depolarisation currents at long times. In contrast, the initial time dependence of these currents is very sensitive on oil conductivity. For this new transformer, the best fit between measured and simulated currents was obtained with conductivity values of 0.29 pS/m for the polarisation current and of 0.255 pS/m for the depolarisation current. This slight decrease of oil conductivity at the end of a polarisation period (from 0.29 pS/m to 0.255 pS/m) is due to a purification effect of the oil [8, 12]. This "non-linear effect", which is typical for new transformers with very low oil conductivity, is manifested by a somewhat lower initial amplitude of the depolarisation current in comparison to that of the polarisation one.

To display the high sensitivity of the initial exponential shape of relaxation currents on a change in oil conductivity, additional simulation have been performed with different oil conductivities, this time holding the properties of the pressboard constant. The results of this simulation are presented in Figure 4. Here, a constant moisture content of 1% was taken for the pressboard, whereas the values of oil conductivity were changed by factors of 0.25 and 4. These results show that the predominant influence of oil conductivity on the initial amplitudes of relaxation currents can well

be used to quantify the oil conductivity of a transformer even without performing direct conductivity measurements on an oil sample.

In summary, the results of Figures 3 and 4 disclose that the moisture content of the pressboard used in this transformer is near 1%. Similar quantitative evaluations have also been done for the *used* unit presented in Figure 2. The results disclose a moisture content of the pressboard of about 1.5% and an oil conductivity of 2.4 pS/m for both polarisation and depolarisation currents at 21 °C.

Polarisation as well as depolarisation currents are directly related to the fundamental dielectric quantities, i.e. the dielectric response function $f(t)$ and dc conductivity of any dielectric. This permits the calculation of other derived dielectric quantities by using simple algorithms. Time domain quantities as e.g.

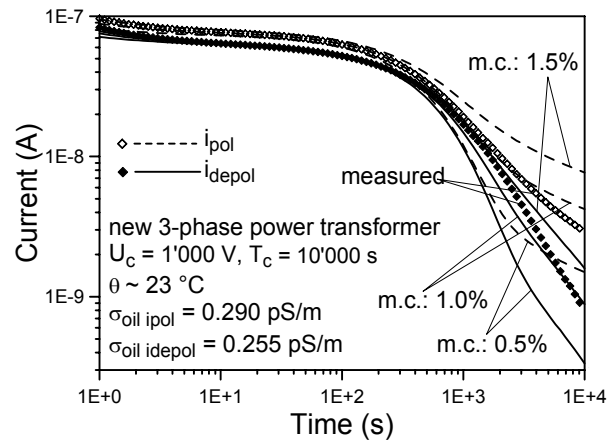

Figure 3: Comparison between measured and calculated polarisation and depolarisation currents as a function of moisture content (m.c.) in the pressboard barriers and spacers of the new transformer of Figure 2.

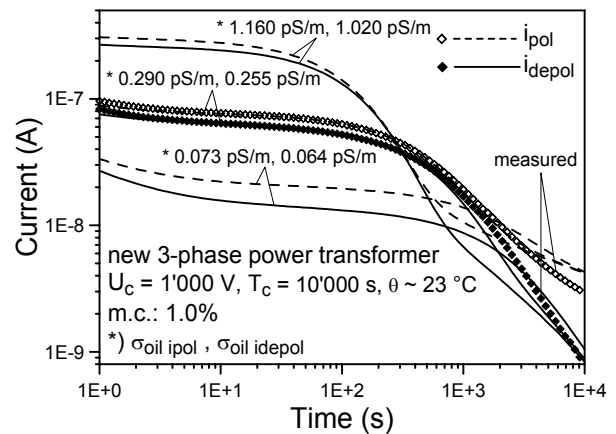

Figure 4: Measured and calculated relaxation currents as a function of oil conductivity σ_{oil} for the new transformer of Figure 2.

recovery voltage, "polarisation spectrum" [13] or complex capacitance [14] can be calculated using an equivalent circuit of parallel RC-elements determined from a single measurement of the polarisation and depolarisation currents [8, 12]. Results of such calculations are presented in Figures 5 and 6.

Figure 5 presents the calculated "polarisation spectra" of the two transformers already presented in Figure 2. Also, both polarisation currents used for the determination of the equivalent circuits are shown. This special representation illustrates that the time position of the main maximum in the "polarisation spectrum", a quantity as defined with the "RVM" method [13], corresponds to the position of the main exponential decay in the relaxation currents. In fact, the investigation performed in [8] disclosed already that the main maximum in the "polarisation spectrum" is due to interfacial polarisation between oil ducts and pressboard barriers and that its positions in time corresponds to the time constant of interfacial polarisation. As this time constant varies with the geometric design (thickness ratio of oil duct to pressboard barrier) and with the oil conductivity, the time position of this maximum in the "polarisation spectrum" cannot be considered as a unique criterion for quantifying the moisture content of pressboard material as used in power transformers. These results disclose also that a single measurement of polarisation and depolarisation currents contains the total information of a "polarisation spectrum", the direct measurement of this latter necessitates a multiple set of time consuming individual charging and discharging steps [13].

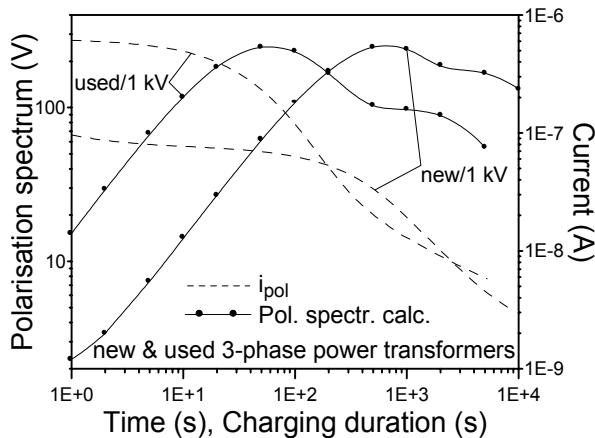

Figure 5: Calculated "polarisation spectra" of the transformers presented in the Figure 2. The calculated spectra are obtained from the measured polarisation currents also presented in this figure.

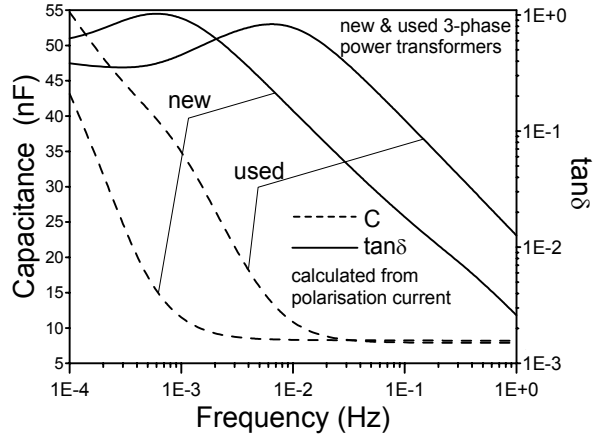

Figure 6: Calculated capacitance and dissipation factor $\tan\delta$ over a wide frequency range of the transformers of Figure 2. The calculated curves are obtained from measured polarisation currents.

Figure 6 shows calculated values of capacitance and $\tan\delta$ for the new and the used transformers. The maximum in the $\tan\delta$ -curve and the significant increase of capacitance at low frequencies confirm once more the predominant influence of the interfacial polarisation on the total dielectric response of the main insulation. Note that a single polarisation current measured for a duration of 5000 s to 10'000 s is sufficient to determine the complex capacitance down to 10^{-4} Hz with low uncertainty.

On-Site PD Measurement Technique

Off-line PD techniques using a mobile, PD-free power source for the excitation of the transformer under test is highly favoured in comparison to on-line methods. As a counter-poise for high expenditures (power source) the advantages of off-line PD-tests are: a low interference level (20 pC to 50 pC background noise level), the opportunity to vary the test voltage and frequency and to excite the transformer in one phase mode [3, 15].

Table 1 shows statistic data of successfully executed off-line PD-tests by FKH since 1993. Within the on-site tested phases roughly in 17% of cases significant PD activity has been found. This means, that the permanent and reproducible PD level was above 50 pC and the performance of the PD pattern showed an interpretable apparent cause that was confirmed by variation of the test voltage and configuration and by comparison of the measurements on all bushings.

An ac-source for the excitation of power transformers on-site (see Figure 7) should grant the following features: transportability, variability of test voltage and frequency and a noise- and PD-free test voltage. Controllable test voltage allows the determination of PD-inception and extinction voltage.

With a test frequency differing from power frequency (50 Hz or 60 Hz) noise generated by power frequency can be discriminated against phase correlated PD-signals. Further on an increased frequency avoids saturation of the iron core at test voltages higher than nominal voltage (U_n).

Figure 8 presents a typical off-line test set-up for PD-signal detection under on-site condition.

Table 1: Overview of executed off-line PD-tests by FKH since 1993 (PD: significant PD activity).

| | | | | | | | |
|----------------------------------|----------|-----------|----------|--------------------|-----------|-----------|--------------|
| Total number of PD-tested phases | | | | | | | |
| 108 | | | | | | | |
| On-Site, off-line | | | | | | | Factory lab. |
| 91 | | | | | | | 17 |
| HV on 400-kV level | | | | HV on 240-kV level | | | |
| 18 | | | | 73 | | | |
| old | | new | | old | | new | |
| 8 | | 10 | | 41 | | 32 | |
| PD | o.k. | PD | o.k. | PD | o.k. | PD | o.k. |
| 1 | 7 | 1 | 9 | 12 | 29 | 1 | 31 |



Figure 8: Off-line test set-up for PD-diagnosis on a 220/65-kV transformer using a 350 kVA diesel generator unit (left hand) and a step up transformer 0.4/65 kV (right hand). Transformer under test with torus electrodes at the HV-bushings to avoid corona discharges, and measuring vehicle (background).

Transfer Function (TF) or Frequency Response Analysis (FRA) Method

Frequency spectra of measured transfer functions (range: 20 Hz to 2 MHz) are sensitive to deformations or displacements of the winding assemblies by dynamic forces originating from excessive mechanical acceleration during transports or by magnetic forces evoked by external short circuit currents [16, 17, 18].

Although a displacement of a winding as it particularly happens with old brittle paper insulation does not necessarily lead to an immediate transformer failure, but it may increase the risk of insulation breakdown on the occasion of the next over-voltage or short circuit stress.

The crucial advantage of the TF- or FRA-method is obviously given through bypassing the costly inspection of the opened transformer.

Early investigations with transfer function relied on time domain measurements, where the signals have been analysed with a digital Fourier transform [17]. In spite of the relative economically priced equipment the frequency domain method is more common, since it exhibits on-site better signal to noise ratios and thus a better sensitivity to small changes.

The principle of FRA-method in frequency domain and the necessary equipment is shown schematically in Figure 9.

The authors use a Hewlett Packard model HP 8751 network analyser for frequency response analysis of transformer windings in frequency domain.

Figure 10 shows the variations for the application of FRA-method, where normally all possible configurations are investigated especially when acquiring the initial reference data.

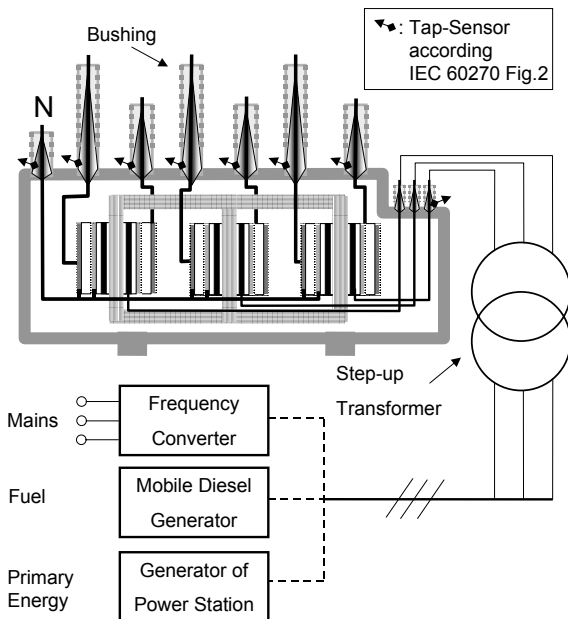

Figure 7: Voltage test on a power transformer using a frequency converter or alternatively a mobile diesel generator or a power station generator in insular operation mode.

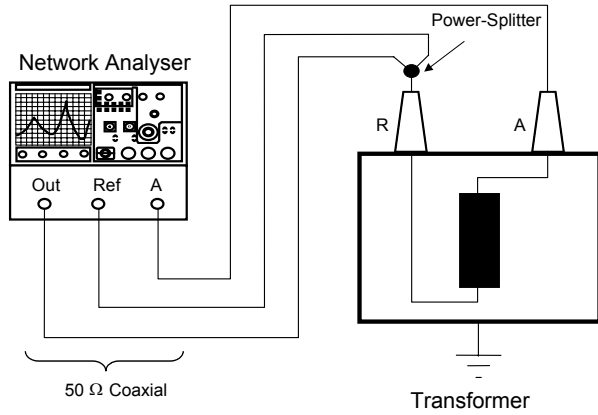

Figure 9: Set-up for frequency response analysis (FRA) in frequency domain.

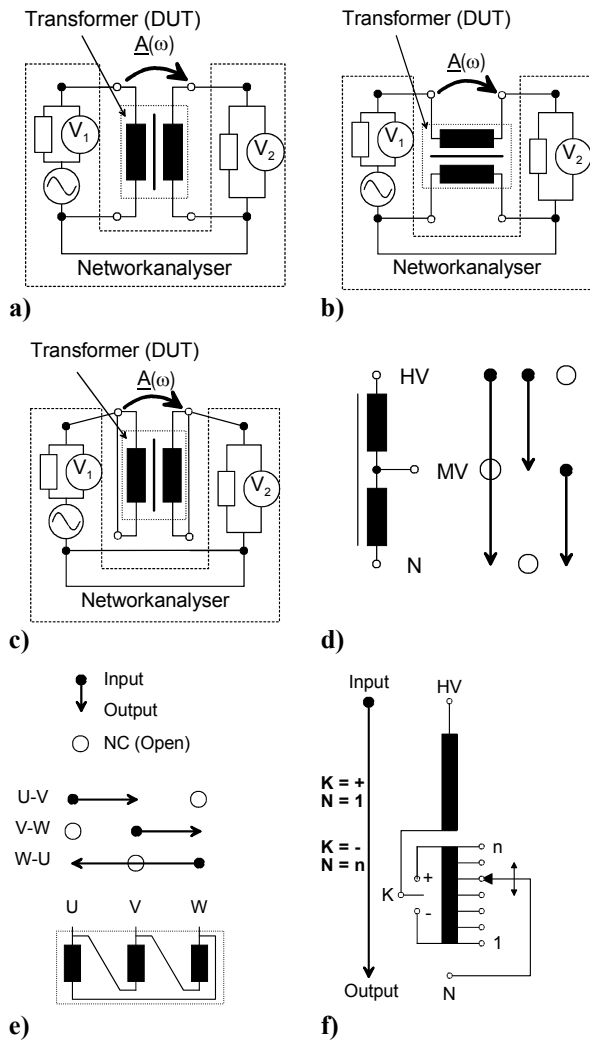

Figure 10: Connection of transformer terminals for: a) transfer function, b) longitudinal transfer function, c) main insulation gap, d) autotransformer winding, e) delta winding, f) regulation winding.

The output of a swept sinusoidal signal and one measuring input (Ref) of the analyser are connected via screened coaxial cables to one terminal of the windings under test. The registered output function is measured as a voltage signal across or between other windings, Figure 10: a), b), c) and e) or an other section of the same winding: d) and f). The input and output impedance of the network analyser affect the frequency spectrum and are therefore consistently kept to 50 Ω .

Our experience has shown, that transfer admittance measurements (voltage to current transfer functions) are normally less sensitivity to small geometrical changes than voltage to voltage transfer measurements are. The reason is, that the necessary current transformers render only a small output signal. Therefore the authors use only the voltage to voltage transfer measurements corresponding to Figure 10.

Up to now the FRA method has been used as a pure comparative method. This means, that neither the relationship between geometrical changes and changes in the spectrum nor the questions of sensitivity to specific displacements have been studied in detail.

Reference data for the required comparison can be achieved by:

1. Earlier measurements, normally at the factory.
2. Measurement of transformers of the same design.
3. Comparison between the three phases or poles.

Figure 11 shows an example of superposed FRA-spectra on the three phases of a 250 MVA power transformer without any indication of a winding

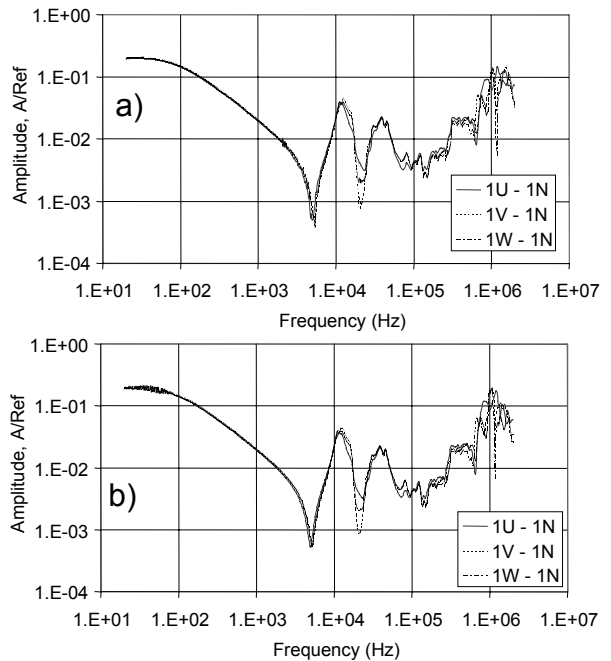

Figure 11: FRA-spectra on all three phases of a 250 MVA transformer a) before shipping and b) after shipping .

displacement. The measurements have been executed before and after the transportation from the manufacturer to the customer on-site. Without a geometrical change the measurements can hardly be distinguished. Compared to this, the difference between the phases is much more significant.

Conclusions

The strong points and the weaknesses of the mentioned methods suggest that the dependability of the results will substantially increase by using a deliberate combination of methods. The selection has to be made according to the technical and operational circumstances. The tests should be arranged in a case dependent sequence in order to achieve the required information necessary for decision making with minimum of expenditure.

PDC measurements are often a starting point for further diagnosis, when high moisture in cellulose insulation is found. Likewise, on-site PD-tests have been initiated in several cases after execution of a gas-in-oil analysis showing high concentration of hydrogen and acetylene.

Well tuned steps finally lead to clear statements that allow to take adequate measures, be it a careful further observation, an inspection at the manufacturer plant or the decision for a total revision of a transformer.

Acknowledgement

Parts of this work has been financially supported by the following institutions of Swiss utilities and industry: PSEL: (Projekt- und Studienfonds der Elektrizitätswirtschaft), RDP-CREE (Recherche, Développement, Prospective, Chambre Romande de l'Energie Electrique).

References

- [1] CIGRE WG 12-05, "An international survey on failures in large power transformers", ELECTRA, No. 88, 1983, pp. 21-48.
- [2] VDEW-Störungsstatistik, edition 1994.
- [3] Th. Aschwanden, M. Hässig, V. Der Houhanessian, W. Zaengl, J. Fuhr, P. Lorin, A. Schenk, P. Zwiackner, A. Piras, J. Dutoit, "Development and Application of New Condition Assessment Methods for Power Transformers", CIGRE Session 1998, Paris, Paper 12-207.
- [4] A. J. Kachler, "One-Site Diagnosis of Power and Special Transformers", Conference Record of the 2000 IEEE International Symposium on Electrical Insulation, IEEE Publication 00CH37075, pp.362-367.
- [5] H. J. Knab, P. Boss, E. Ecknauer, R. Gysi, "Diagnostic tools for transformer in service", CIGRE Symposium, Berlin, 1993, Paper 110-05.
- [6] H. J. Knab, "Die Betriebsüberwachung von Transformatoren", Bulletin SEV/VSE 21/96, pp. 41-47.
- [7] A. De Pablo, A. Möllmann, "New guidelines for Furans analysis as well as dissolved gasanalysis in oil-filled transformers", CIGRE 1996, 15/21/33.
- [8] V. Der Houhanessian, *Measurement and Analysis of Dielectric Response in Oil-Paper Insulation System*, Ph. D. dissertation, ETH No. 12832, Zurich, 1998.
- [9] Electrical Insulation Diagnostic System PDC-ANALYSER-1MOD, ALFF ENGINEERING, Gomweg 7, CH-8915 Hausen am Albis, Switzerland, (alff@engineer.com).
- [10] J.-J. Alff, V. Der Houhanessian, W. S. Zaengl, A. J. Kachler, "A Novel, Compact Instrument for the Measurement and Evaluation of Relaxation Currents conceived for On-Site Diagnosis of Electric Power Apparatus", Conference Record of the 2000 IEEE International Symposium on Electrical Insulation, IEEE Publication 00CH37075, pp. 161-167.
- [11] V. Der Houhanessian, W. S. Zaengl, "On-site diagnosis of power transformers by means of relaxation current measurements", Conference Record of the 1998 IEEE International Symposium on Electrical Insulation, IEEE Publication 98CH36239, pp. 28-34.
- [12] V. Der Houhanessian, W. S. Zaengl, "Application of relaxation current measurements to on-site diagnosis of power transformers", Annual Report of the 1997 Conference on Electrical Insulation and Dielectric Phenomena, IEEE Publication 97CH36046, pp. 45-51.
- [13] Tettex Instruments AG, "Polarisation spectrum analysis for diagnosis of insulation systems", Information 29, 1992, TI 29-d/e-04. 92.
- [14] A. K. Jonscher, *Dielectric relaxation in solids*, Chelsea Dielectric Press, London 1983, ISBN 0 9508711 0 9.
- [15] R. Bräunlich, M. Hässig, J. Fuhr, Th. Aschwanden, "Assessment of insulation condition of large power transformer by on-site electrical diagnostic methodes", Conf. Record of the 2000 IEEE Inter. Symposium on Electrical Insulation, IEEE Publication 00CH37075, pp.368-372.
- [16] E. P. Dick, C. C. Erven, "Transformer diagnostic testing by frequency response analysis", IEEE Trans. PAS, vol. 97 1978 pp. 2144-2153.
- [17] R. Malewski, J. Douville, G. Bélanger, "Insulation diagnostic system for HV power transformers in service", CIGRE 1986, 12-01.
- [18] J. A. Lappworth, P. N. Jahrmann, "Winding movement detection in power transformers by frequency response analysis (FRA)", Proc. Conference on Condition Monitoring in HV substations, Dorking, U. K. 1996.

Author address: Martin Hässig, FKH Fachkommission für Hochspannungsfragen, Voltastrasse 9, CH-8044 Zurich, Switzerland, Email: haessig@fkh.ch.

For inquiries concerning PDC-analyser, please contact:
ALFF ENGINEERING
 Gomweg 7, CH-8915 Hausen am Albis, Switzerland
 phone: +41 1 77 66 77 6, fax: +41 1 77 66 77 7
info@alff-engineering.ch www.alff-engineering.ch